

# COMPUTER PHONE WIRING

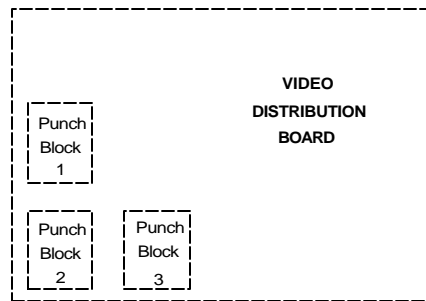
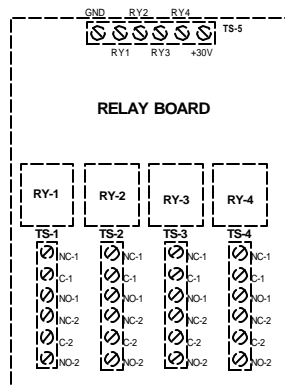
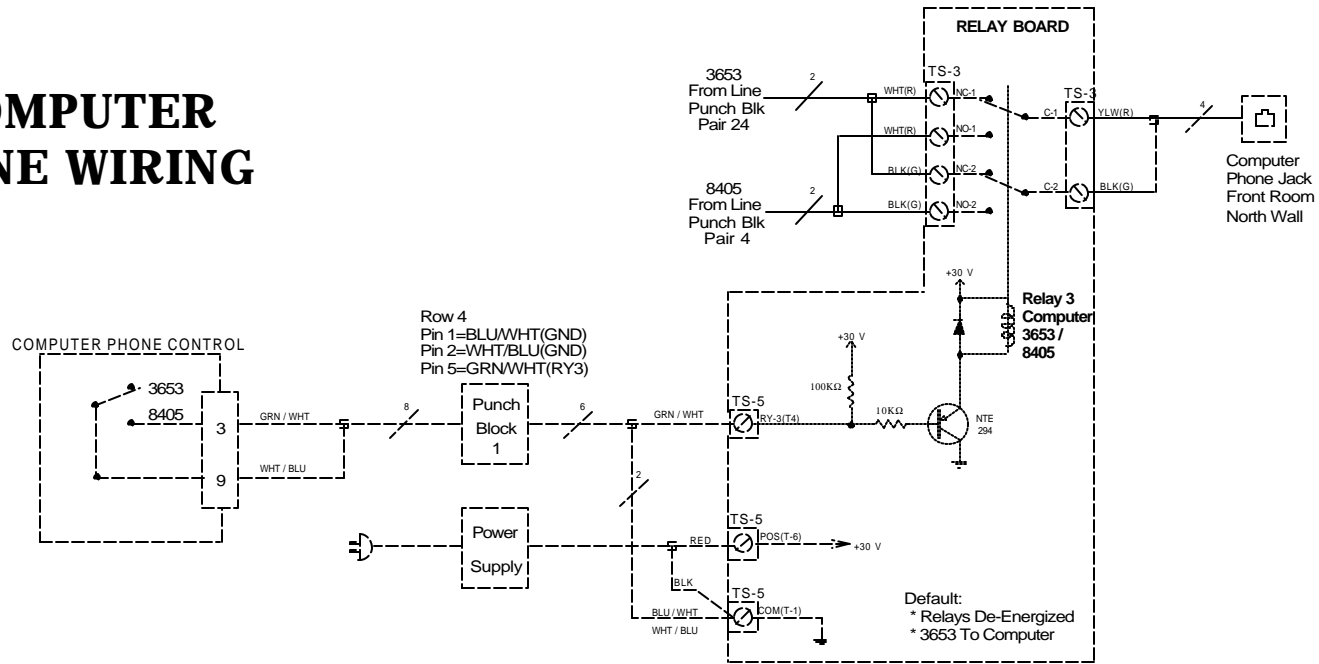

COMPUTER PHONE WIRING	
Designer: JOHN SCHMITZ	Date: 21 September 96
<i>John R. Schmitz</i>	Version: 01.00.00
This circuit allows the computer modem to be swithed between the 3653 (default) phone line and the 8405 phone line	